



Technical Data Sheet



Project Location
United Arab Emirates

Customer
Trielectric International FZE

Contact
Mr.Saravanan(+971564345964)

Contact
Mr.Tamil(+971502353763)

Item name
1.00015

Our ref.
Stock

Rev/Changed by
A

Date of issue
9/14/2021

Saving ident

Pages
1(3)

No.	Definition	Data	Unit	Remarks
1	Product	TEFC, 3-phase, squirrel cage induction motor		
2	Product code	3GBA 201 410-BDCIN		
3	Type/Frame	M2BAX 200MLA 2		
4	Mounting	IM3001, B5(flange)		
5	Rated output P _N	30	kW	
6	Service factor	1		
7	Type of duty	S1 100%		
8	Rated voltage U _N	400	VD	± 5 %
9	Rated frequency f _N	50	Hz	± 2 %
10	Rated speed n _N	2935	r/min	
11	Rated current I _N	53.4	A	
12				
13	Starting current I _s /I _N	7		
14	Nominal torque T _N	98	Nm	
15	Locked rotor torque T _s /T _N	2.2		
16	Maximum torque T _{max} /T _N	3.2		
17				
18				
	Load characteristics	Load %	Current A	Efficiency % Power factor
19	PLL determined from residual loss	100	53.4	92.0 / IE2 0.88
20		75	40.9	92.4 0.86
21		50	30	91.5 0.79
22				
23	Thermal withstand time hot	13	s	
24	Thermal withstand time cold	21	s	
25	Insulation class / Temperature class	F / B		
26	Ambient temperature	50	°C	
27	Altitude	1000	m.a.s.l.	
28	Degree of protection	IP55		
29	Cooling system	IC411		
30	Bearing DE/NDE	6312-2Z/C3 - 6209-2Z/C3		
31	Sound pressure level (LP dB(A) 1m)	85	dB(A)	at no-load
32	Moment of inertia J = ¼ GD2	0.1077	kg-m2	
33	Position of terminal box	Top		
34	Direction of rotation	Bi-directional		
35	Weight of rotor	46	kg	
36	Total weight of motor	198	kg	
37	Paint shade	Munsell Blue		
38	Cable size			
39	Vibration	As Per IS 12075		
40				
41				
42				
43				
44				
45				
46	Ex-motors			
47				
48				

Option Variant Codes / Definition

49
50
51
52

Remarks:

Applicable standards: IS 12615:2018, IEC 60034-30-1:2014

All performance values are subject to IS/IEC tolerances

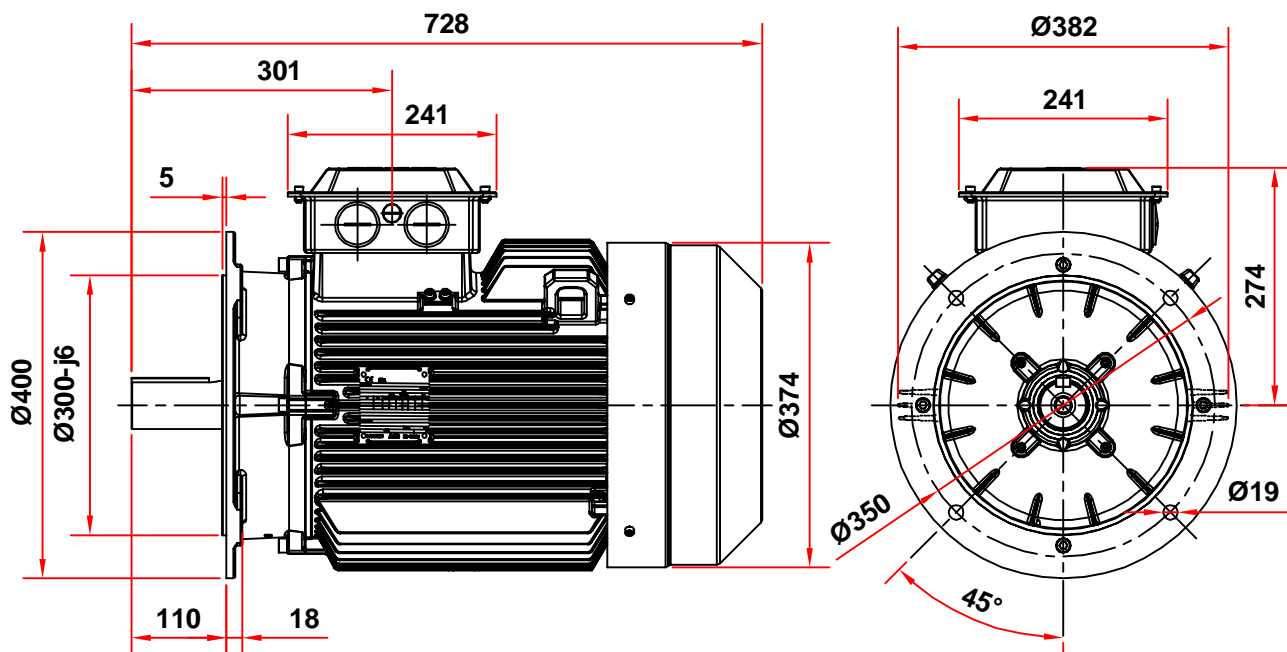
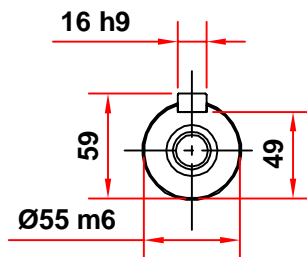
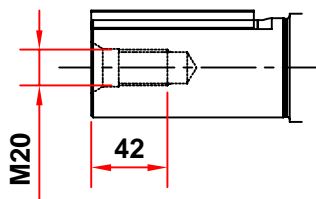

Motor Dimension Print

Motor Type :

M2BAX 200 Short B5,V1,V3

Document N° :

3GZH500020-3

Description :

Motor IE2 flange mounted IM3001



Unit : ABB, LV Motors, India

Issued by : DANISH

Replaces :

Date : 2015-10-07

Approved by : SA

Replaced by :

Motors in brief

General performance IE2 high efficiency cast iron motors

Size	160	180	200	225	250	
Stator	Material	Cast iron grade 200 : ISO 185				
	Paint colour shade	Munsell blue 8B 4.5/3.25 / NCS 4822 B05G				
	Surface Treatment	C3 medium according to ISO / EN 12944-5				
Feet		Integrated with stator				
	Material	Cast iron grade 200 : ISO 185				
Bearing end shields	Material	Cast iron grade 200 : ISO 185				
	Paint colour shade	Munsell blue 8B 4.5/3.25 / NCS 4822 B05G				
	Surface Treatment	Aliphatic polyurethane enamel paint_70µm				
Bearings	D-end	6209-2Z/C3	6310-2Z/C3	6312-2Z/C3	6313-2Z/C3	6315-2Z/C3
	N-end	6209-2Z/C3	6209-2Z/C3	6209-2Z/C3	6210-2Z/C3	6212-2Z/C3
Axially-locked	Inner Bearing Cover	As standard, locked at D-end				
Bearing seals	D-end	V-ring				
	N-end	V-ring				
Lubrication		Permanently lubricated shielded bearings				
Terminal Box	Material	Sheet of Steel, Cold Rolled				
	Surface	Treatment Similar to stator				
	Screws	Steel 8.8				
Connections	Cable Entries	2xM40, 1xM16			2xM50, 1xM16	
	Cable Sizes	2Rx3Cx70mm ²			2Rx3Cx120mm ²	
	Terminal Stud Size	M6			M10	
	Terminal Box	6 terminals for connection, cable lugs (not included)				
Fan	Material	Polypropylene, Reinforced with 20% glass fibre				
Fan Cover	Material	Sheet of Steel, Cold Rolled				
	Paint colour shade	Munsell blue 8B 4.5/3.25 / NCS 4822 B05G				
	Surface Treatment	Similar to stator				
Stator winding	Material	Copper				
	Insulation	Insulation class F				
Rotor winding	Material	Diecast aluminum				
Balancing method		Half Key Balancing as standard				
Key ways		Open Key Way				
Enclosure		IP 55				
Cooling method		IC 411				
Drain holes		Drain holes with closable plastic plugs, open on delivery				
Lifting lugs		Integrated with the stator				