



Technical Data Sheet



Project Location
United Arab Emirates

Customer
Trielectric International FZE

Contact
Mr.Saravanan(+971564345964)

Contact
Mr.Tamil(+971502353763)

Item name
1.00013

Our ref.
Stock

Rev/Changed by
A

Date of issue
9/14/2021

Saving ident

Pages
1(3)

No.	Definition	Data	Unit	Remarks
1	Product	TEFC, 3-phase, squirrel cage induction motor		
2	Product code	3GBA 161 430-BDCIN		
3	Type/Frame	M2BAX 160MLC 2		
4	Mounting	IM3001, B5(flange)		
5	Rated output P _N	18.5	kW	
6	Service factor	1		
7	Type of duty	S1 100%		
8	Rated voltage U _N	400	VD	± 5 %
9	Rated frequency f _N	50	Hz	± 2 %
10	Rated speed n _N	2928	r/min	
11	Rated current I _N	33.6	A	
12				
13	Starting current I _s /I _N	7		
14	Nominal torque T _N	60	Nm	
15	Locked rotor torque T _s /T _N	2.3		
16	Maximum torque T _{max} /T _N	3		
17				
18				
	Load characteristics	Load %	Current A	Efficiency % Power factor
19	PLL determined from residual loss	100	33.6	90.9 / IE2 0.87
20		75	25.8	91.2 0.85
21		50	18.5	90.4 0.8
22				
23	Thermal withstand time hot	19	s	
24	Thermal withstand time cold	31	s	
25	Insulation class / Temperature class	F / B		
26	Ambient temperature	50	°C	
27	Altitude	1000	m.a.s.l.	
28	Degree of protection	IP55		
29	Cooling system	IC411		
30	Bearing DE/NDE	6209-2Z/C3 - 6209-2Z/C3		
31	Sound pressure level (LP dB(A) 1m)	85	dB(A)	at no-load
32	Moment of inertia J = ¼ GD2	0.0581	kg-m2	
33	Position of terminal box	Top		
34	Direction of rotation	Bi-directional		
35	Total weight of motor	131	kg	
36	Paint shade	Munsell Blue		
37	Cable size			
38	Vibration	As Per IS 12075		
39				
40				
41				
42				
43				
44				
45				
Ex-motors				
46				
47				
48				
Option Variant Codes / Definition				
49				
50				
51				
52				

Remarks:

Applicable standards: IS 12615:2018, IEC 60034-30-1:2014

All performance values are subject to IS/IEC tolerances

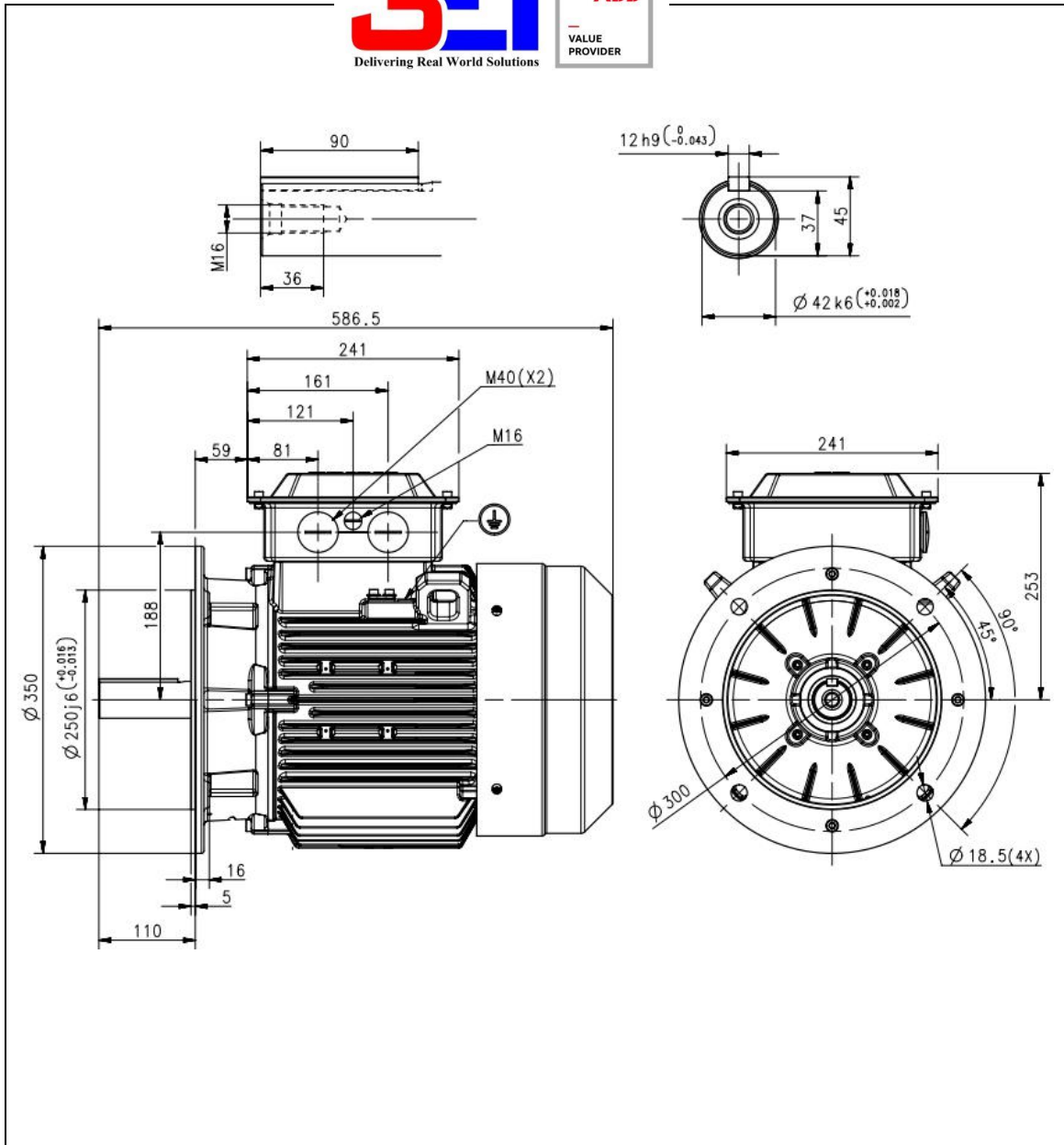

Additional information:

Dimension Print	Motor Type: M2BAX 160MLA2 160MLA4 160MLA6 160MLB2 160MLB4 160MLC2 B5, V1, V3	Document No: 3GZC500016-9 E 13 BA 160 A
	Description: STANDARD SQUIRREL CAGE MOTOR	
Unit: ABB Motors and Generators	Issued by: Bin Zou	Replaces:
Date: 2015-08-11	Approved by: Anna Feng	Replaced by:
ABB Ltd.	Customer Reference:	ABB

Motors in brief

General performance IE2 high efficiency cast iron motors

Size	160	180	200	225	250	
Stator	Material	Cast iron grade 200 : ISO 185				
	Paint colour shade	Munsell blue 8B 4.5/3.25 / NCS 4822 B05G				
	Surface Treatment	C3 medium according to ISO / EN 12944-5				
Feet		Integrated with stator				
	Material	Cast iron grade 200 : ISO 185				
Bearing end shields	Material	Cast iron grade 200 : ISO 185				
	Paint colour shade	Munsell blue 8B 4.5/3.25 / NCS 4822 B05G				
	Surface Treatment	Aliphatic polyurethane enamel paint_70µm				
Bearings	D-end	6209-2Z/C3	6310-2Z/C3	6312-2Z/C3	6313-2Z/C3	6315-2Z/C3
	N-end	6209-2Z/C3	6209-2Z/C3	6209-2Z/C3	6210-2Z/C3	6212-2Z/C3
Axially-locked	Inner Bearing Cover	As standard, locked at D-end				
Bearing seals	D-end	V-ring				
	N-end	V-ring				
Lubrication		Permanently lubricated shielded bearings				
Terminal Box	Material	Sheet of Steel, Cold Rolled				
	Surface	Treatment Similar to stator				
	Screws	Steel 8.8				
Connections	Cable Entries	2xM40, 1xM16			2xM50, 1xM16	
	Cable Sizes	2Rx3Cx70mm ²			2Rx3Cx120mm ²	
	Terminal Stud Size	M6			M10	
	Terminal Box	6 terminals for connection, cable lugs (not included)				
Fan	Material	Polypropylene, Reinforced with 20% glass fibre				
Fan Cover	Material	Sheet of Steel, Cold Rolled				
	Paint colour shade	Munsell blue 8B 4.5/3.25 / NCS 4822 B05G				
	Surface Treatment	Similar to stator				
Stator winding	Material	Copper				
	Insulation	Insulation class F				
Rotor winding	Material	Diecast aluminum				
Balancing method		Half Key Balancing as standard				
Key ways		Open Key Way				
Enclosure		IP 55				
Cooling method		IC 411				
Drain holes		Drain holes with closable plastic plugs, open on delivery				
Lifting lugs		Integrated with the stator				