



## Technical Data Sheet - DOL



Project Location  
**United Arab Emirates**

Company <b>Trielectric International FZE</b>	Contact <b>Mr.Saravanan(+971564345964)</b>	Contact <b>Mr.Thamizh(+971502353763)</b>	Item name <b>1.00003</b>
Our ref. <b>Stock</b>	Rev/Changed by <b>A</b>	Date of issue <b>9/15/2021</b>	Saving ident <b>Pages</b> <b>1(3)</b>

No.	Definition	Data	Unit	Remarks
1	Product	<b>TEFC, 3-phase, squirrel cage induction motor</b>		
2	Product code	<b>3GAA 082 315-ASE</b>		Calc. ref. GEN_3GAA082315-E_S
3	Type/Frame	<b>M3AA 80E 4</b>		
4	Mounting	<b>IM1001, B3(foot)</b>		
5	Rated output P <sub>N</sub>	<b>0.75</b>	kW	
6	Service factor	<b>1</b>		
7	Type of duty	<b>S1(IEC) 100%</b>		
8	Rated voltage U <sub>N</sub>	<b>400</b>	VY	± 5 % (IEC 60034-1)
9	Rated frequency f <sub>N</sub>	<b>50</b>	Hz	± 2 % (IEC 60034-1)
10	Rated speed n <sub>N</sub>	<b>1425</b>	r/min	
11	Rated current I <sub>N</sub>	<b>1.88</b>	A	
12	No-load current	<b>1.26</b>	A	
13	Starting current I <sub>s</sub> /I <sub>N</sub>	<b>6.6</b>		Meet IEC 60034-12, N,(H at 60 Hz)
14	Nominal torque T <sub>N</sub>	<b>5</b>	Nm	
15	Locked rotor torque T <sub>s</sub> /T <sub>N</sub>	<b>3.5</b>		
16	Maximum torque T <sub>max</sub> /T <sub>N</sub>	<b>3.6</b>		
17	Minimum torque T <sub>min</sub> /T <sub>N</sub>	<b>2.7</b>		
18	Speed at minimum torque	<b>195</b>	r/min	
Load characteristics (IEC 60034-2-1:2014)		Load %	Current A	Efficiency %
19	PLL determined from residual loss	<b>100</b>	<b>1.88</b>	<b>79.8 / IE2</b>
20		<b>75</b>	<b>1.63</b>	<b>80.4</b>
21		<b>50</b>	<b>1.42</b>	<b>77.9</b>
22		<b>Start</b>	<b>12.4</b>	<b>0.74</b>
23	Maximum starting time from hot	<b>20</b>	s	
24	Maximum starting time from cold	<b>36</b>	s	
25	Insulation class / Temperature class	<b>F / B</b>		
26	Ambient temperature	<b>40</b>	°C	
27	Altitude	<b>1000</b>	m.a.s.l.	
28	Enclosure	<b>IP55</b>		
29	Cooling system	<b>IC411 self ventilated</b>		
30	Bearing DE/NDE	<b>6204-2Z/C3 - 6203-2Z/C3</b>		
31	Type of Grease			
32	Sound pressure level (LP dB(A) 1m)	<b>54</b>	dB(A)	at load
33	Moment of inertia J = ¼ GD <sup>2</sup>	<b>0.002</b>	kg-m <sup>2</sup>	
34	Balancing			
35	Vibration class			
36	Position of terminal box	<b>Top</b>		
37	Terminal box entries; no, dimens.			
38	Number of power terminals			
39	Direction of rotation	<b>CW or CCW</b>		
40	Weight of rotor	<b>4</b>	kg	
41	Total weight of motor	<b>15</b>	kg	
42	Dimension drawing no.			
43				
44				
45				
Ex-motors				
46				
47				
48				

**Option Variant Codes / Definition**



49	
50	
51	
52	

Remarks:

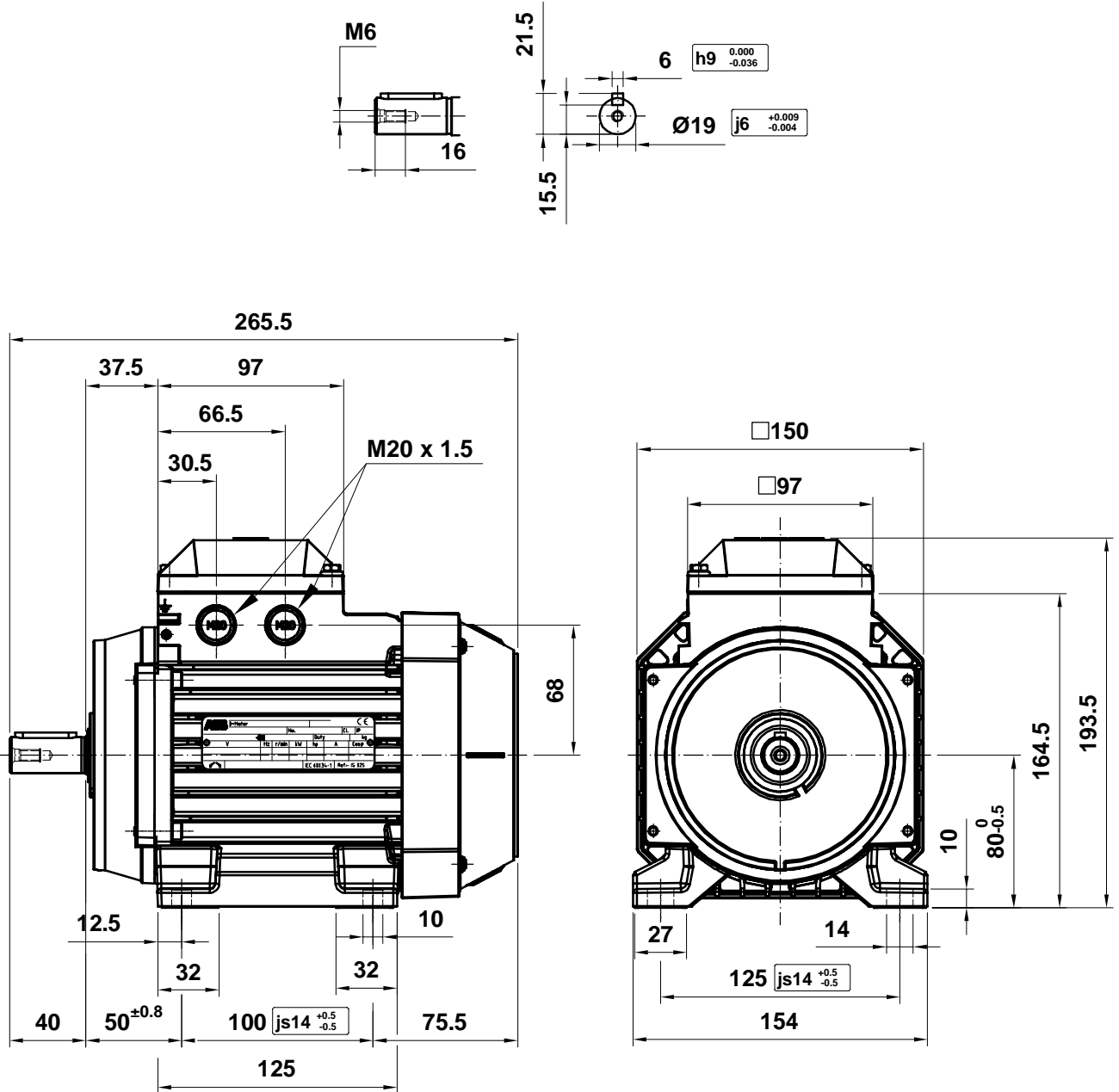
Data based on situation 3/7/2019  
All data subject to tolerances in accordance with IEC  
Guaranteed values on request

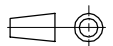

# M3AA 080

<b>Motor Dimension Print</b>	Motor Type : <b>M3AA 080</b>	Document N° : <b>A1.5015 / 3D A2.5015</b>
Description : <b>Motor foot mounted IM1001 / Motor con patas IM1001</b>		
Unit : <b>Discrete Automation &amp; Motion - Fáb. Motores</b> Date : <b>2012-01-26</b>	Issued by : <b>ERM/J.L. Bayo</b> Approved by : <b>ERM/G.Blanes</b>	Replaces : <b>To date 2009-03-18</b> Replaced by :
<b>Asea Brown Boveri, S.A.</b>	Customer Reference :	

# Motors in brief

## Motor sizes 56–132

Motor size	M3AA	56–63	71	80	90	100	112	132	
Stator and end shields	Material	Die-cast aluminum alloy							
	Paint colour shade	Munsell blue 8B 4.5/3.25							
	Corrosion class	C3 according to IEO/EN 12944-5							
Feet	Integrated aluminum feet								
Bearings	D-end	6201-2Z/C3	6203-2Z/C3	6204-2Z/C3	6205-2Z/C3	6306-2Z/C3	6306-2Z/C3	6208-2Z/C3	
									6308-2Z/C3 <sup>1)</sup>
									E2.6208-2Z/C3 <sup>2)</sup>
								E2.6308-2Z/C3 <sup>3)</sup>	
	N-end	6201-2Z/C3	6202-2Z/C3	6203-2Z/C3	6204-2Z/C3	6205-2Z/C3	6205-2Z/C3	6206-2Z/C3	
									E2.6206-2Z/C3 <sup>4)</sup>
Axially-locked bearings	Inner bearing cover	ND-end retaining ring	Locked at D-end						
Bearing seal	D-end	V-ring							
	N-end	Labyrinth seal							
Lubrication	Permanent grease lubrication. Grease temperature range -40°C to +160°C								
Measuring nipples for condition monitoring of the bearings	Not included								
Rating plate	Material	Aluminum							
Terminal box	Material	Die-cast aluminum alloy, integrated to stator							
	Cover screws material	Zinc-electroplated steel							
Connections	Openings	2x(M16+M16)	2x(M20 + M20)	2x(M20+M25)				2x(M20+M25) <sup>5)</sup>	
									2x(M40+M32+M12) <sup>6)</sup>
		Terminals	6 terminals for connection with cable lugs (not included)						
	Cable glands	Optional							
Fan	Material	Glass-fiber reinforced polypropylene							
Fan cover	Material	Polypropylene							
	Paint colour shade	Munsell blue 8B 4.5/3.25							
	Corrosion class	C3							
Stator winding	Material	Copper							
	Insulation	Insulation class F							
	Winding protection	Optional							
Rotor winding	Material	Die-cast aluminum							
Balancing	Half key balancing								
Key ways	Closed key way								
Drain holes	Without drain holes		Drain holes with closable plastic plugs, open on delivery						
External earthing bolt	As option								
Enclosure	IP 55								
Cooling method	IC 411								

<sup>1)</sup> (SM) except 4p 11&15kW HO

<sup>4)</sup> HO 2p 9,2&15kW

<sup>2)</sup> 2p 9,2kW HO

<sup>5)</sup> S, SB, M, MA

<sup>3)</sup> 2p 15kW HO

<sup>6)</sup> SC, MC, SMA-SME