



## Technical Data Sheet - DOL



Project Location  
**United Arab Emirates**

Company **Trielectric International FZE** Contact **Mr.Saravanan(+971564345964)** Contact **Mr.Thamizh(+91502353763)** Item name **1.00002**

Our ref. **Stock** Rev/Changed by **A** Date of issue **9/15/2021** Saving ident Pages **1(3)**

No.	Definition	Data	Unit	Remarks
1	Product	<b>TEFC, 3-phase, squirrel cage induction motor</b>		
2	Product code	<b>3GAA 083 313-BSE</b>		Calc. ref. 3GZF021008-594
3	Type/Frame	<b>M3AA 80C 6</b>		
4	Mounting	<b>IM3001, B5(flange)</b>		
5	Rated output P <sub>N</sub>	<b>0.55</b>	kW	
6	Service factor	<b>1</b>		
7	Type of duty	<b>S1(IEC) 100%</b>		
8	Rated voltage U <sub>N</sub>	<b>400</b>	VY	± 5 % (IEC 60034-1)
9	Rated frequency f <sub>N</sub>	<b>50</b>	Hz	± 2 % (IEC 60034-1)
10	Rated speed n <sub>N</sub>	<b>905</b>	r/min	
11	Rated current I <sub>N</sub>	<b>1.42</b>	A	
12	No-load current	<b>0.82</b>	A	
13	Starting current I <sub>s</sub> /I <sub>N</sub>	<b>4.4</b>		Meet IEC 60034-12, N,(H at 60 Hz)
14	Nominal torque T <sub>N</sub>	<b>5.8</b>	Nm	
15	Locked rotor torque T <sub>s</sub> /T <sub>N</sub>	<b>2.7</b>		
16	Maximum torque T <sub>max</sub> /T <sub>N</sub>	<b>2.6</b>		
17	Minimum torque T <sub>min</sub> /T <sub>N</sub>	<b>2.5</b>		
18	Speed at minimum torque	<b>150</b>	r/min	
Load characteristics (IEC 60034-2-1:2014)		Load %	Current A	Efficiency %
19	PLL determined from residual loss	<b>100</b>	<b>1.42</b>	<b>73.1 / IE2</b>
20		<b>75</b>	<b>1.19</b>	<b>75.9</b>
21		<b>50</b>	<b>1</b>	<b>75.1</b>
22		<b>Start</b>	<b>6.2</b>	<b>0.76</b>
23	Maximum starting time from hot	<b>40</b>	s	
24	Maximum starting time from cold	<b>72</b>	s	
25	Insulation class / Temperature class	<b>F / B</b>		
26	Ambient temperature	<b>40</b>	°C	
27	Altitude	<b>1000</b>	m.a.s.l.	
28	Enclosure	<b>IP55</b>		
29	Cooling system	<b>IC411 self ventilated</b>		
30	Bearing DE/NDE	<b>6204-2Z/C3 - 6203-2Z/C3</b>		
31	Type of Grease			
32	Sound pressure level (LP dB(A) 1m)	<b>47</b>	dB(A)	at load
33	Moment of inertia J = ¼ GD <sup>2</sup>	<b>0.0034</b>	kg-m <sup>2</sup>	
34	Balancing			
35	Vibration class			
36	Position of terminal box	<b>Top</b>		
37	Terminal box entries; no, dimens.			
38	Number of power terminals			
39	Direction of rotation	<b>CW or CCW</b>		
40	Weight of rotor	<b>4</b>	kg	
41	Total weight of motor	<b>15</b>	kg	
42	Dimension drawing no.			
43				
44				
45				

### Ex-motors

46				
47				
48				

### Option Variant Codes / Definition



49				
50				
51				
52				

### Remarks:

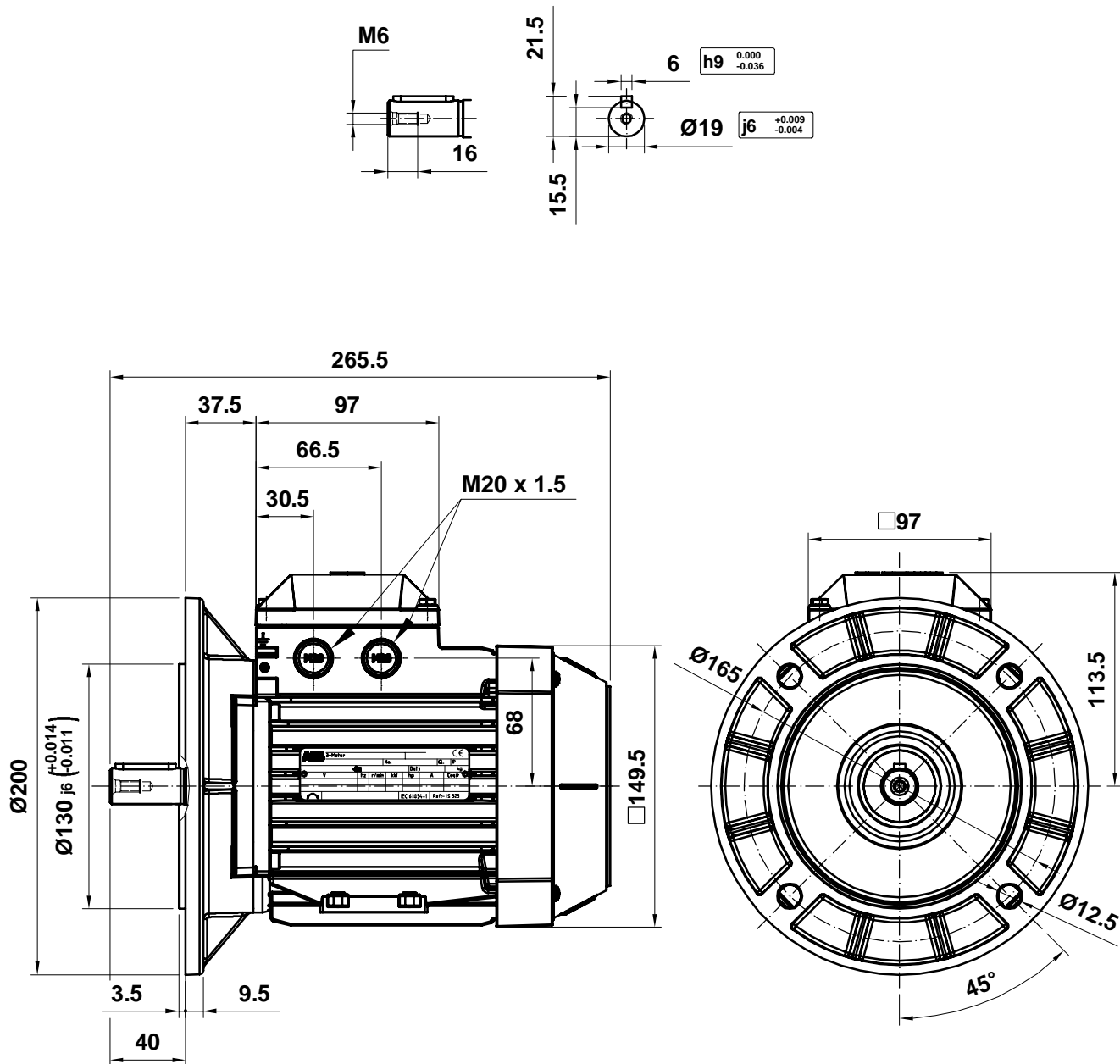
Data based on situation 2/27/2021  
All data subject to tolerances in accordance with IEC  
Guaranteed values on request

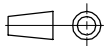

# M3AA 080

<b>Motor Dimension Print</b>	Motor Type : <b>M3AA 080</b>	Document N° : <b>A1.5016 / 3D A2.5016</b>
Description : <b>Motor flange mounted IM3001 / Motor con brida IM3001</b>		
Unit : <b>Discrete Automation &amp; Motion - Fáb. Motores</b> Date : <b>2012-01-26</b>	Issued by : <b>ERM/J.Muñoz</b> Approved by : <b>ERM/G.Blanes</b>	Replaces : <b>To date 2009-05-05</b> Replaced by :
<b>Asea Brown Boveri, S.A.</b>	Customer Reference :	
		

# Motors in brief

## Motor sizes 56–132

Motor size	M3AA	56–63	71	80	90	100	112	132
Stator and end shields	Material	Die-cast aluminum alloy						
	Paint colour shade	Munsell blue 8B 4.5/3.25						
	Corrosion class	C3 according to IEO/EN 12944-5						
Feet	Integrated aluminum feet							
Bearings	D-end	6201-2Z/C3	6203-2Z/C3	6204-2Z/C3	6205-2Z/C3	6306-2Z/C3	6306-2Z/C3	6208-2Z/C3
								E2.6208-2Z/C3 <sup>2)</sup>
Axially-locked bearings	N-end	6201-2Z/C3	6202-2Z/C3	6203-2Z/C3	6204-2Z/C3	6205-2Z/C3	6205-2Z/C3	6206-2Z/C3
	Inner bearing cover	ND-end retaining ring	Locked at D-end					
Bearing seal	D-end	V-ring						
	N-end	Labyrinth seal						
Lubrication	Permanent grease lubrication. Grease temperature range -40°C to +160°C							
Measuring nipples for condition monitoring of the bearings	Not included							
Rating plate	Material	Aluminum						
Terminal box	Material	Die-cast aluminum alloy, integrated to stator						
	Cover screws material	Zinc-electroplated steel						
Connections	Openings	2x(M16+M16)	2x(M20 + M20)	2x(M20+M25)			2x(M20+M25) <sup>5)</sup>	
	Terminals	6 terminals for connection with cable lugs (not included)						
Cable glands	Optional							
Fan	Material	Glass-fiber reinforced polypropylene						
Fan cover	Material	Polypropylene						
	Paint colour shade	Munsell blue 8B 4.5/3.25						
	Corrosion class	C3						
Stator winding	Material	Copper						
	Insulation	Insulation class F						
	Winding protection	Optional						
Rotor winding	Material	Die-cast aluminum						
Balancing	Half key balancing							
Key ways	Closed key way							
Drain holes	Without drain holes		Drain holes with closable plastic plugs, open on delivery					
External earthing bolt	As option							
Enclosure	IP 55							
Cooling method	IC 411							

<sup>1)</sup> (SM) except 4p 11&15kW HO

<sup>4)</sup> HO 2p 9,2&15kW

<sup>2)</sup> 2p 9,2kW HO

<sup>5)</sup> S, SB, M, MA

<sup>3)</sup> 2p 15kW HO

<sup>6)</sup> SC, MC, SMA-SME