

ABB product IEC quick reference chart

Leading provider of energy efficient industrial electric motors and drives.

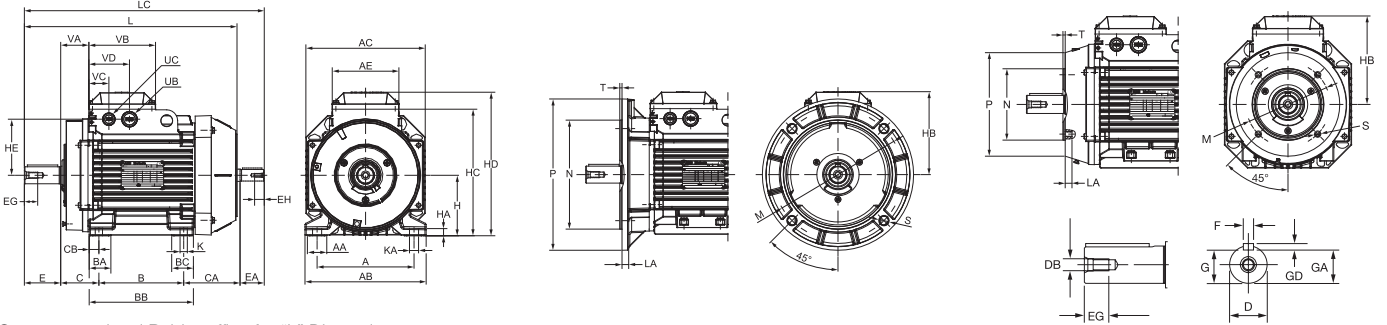

Contact your local Baldor office for "L" Dimensions.

IEC Frame	Foot Mounted			Shaft			B5 Flange			B14 Face									
	A	B	B'	H	D	E	DB	EG	LA	M	N	P	S	T	M	N	P	S	T
63	100mm	80mm	-	63mm	11mm	23mm	M4	10mm	10mm	115mm	95mm	120mm	7mm	3mm	75mm	60mm	90mm	M5	2.5mm 0.10"
71	112mm	90mm	-	71mm	14mm	30mm	M5	12.5mm	9mm	130mm	110mm	160mm	10mm	3.5mm	85mm	70mm	105mm	M6	2.5mm 0.10"
80	125mm	100mm	-	80mm	19mm	40mm	M6	16mm	10mm	165mm	130mm	200mm	12mm	3.5mm	100mm	80mm	120mm	M6	3mm 0.12"
90S	140mm	100mm	-	90mm	24mm	50mm	M8	19mm	10mm	165mm	130mm	200mm	12mm	3.5mm	115mm	95mm	140mm	M8	3mm 0.12"
90L	140mm	125mm	-	90mm	24mm	50mm	M8	19mm	10mm	165mm	130mm	200mm	12mm	3.5mm	115mm	95mm	140mm	M8	3mm 0.12"
100	160mm	140mm	-	100mm	28mm	60mm	M10	22mm	11mm	215mm	180mm	250mm	15mm	4mm	130mm	110mm	160mm	M8	3.5mm 0.14"
112	190mm	140mm	-	112mm	28mm	60mm	M10	22mm	11mm	215mm	180mm	250mm	15mm	4mm	130mm	110mm	160mm	M8	3.5mm 0.14"
132	216mm	140mm	178mm	132mm	38mm	80mm	M12	28mm	12.5mm	265mm	230mm	300mm	15mm	4mm	165mm	130mm	200mm	M10	3.5mm 0.14"
160	254mm	210mm	254mm	160mm	42mm	110mm	M16	36mm	20mm	300mm	250mm	350mm	19mm	5mm	215mm	180mm	250mm	M12	4mm 0.16"
180	279mm	241mm	279mm	180mm	48mm	110mm	M16	36mm	20mm	300mm	250mm	350mm	19mm	5mm	-	-	-	-	-
200	318mm	267mm	305mm	200mm	55mm	110mm	M20	42mm	20mm	350mm	300mm	400mm	19mm	5mm	-	-	-	-	-
225 S	356mm	286mm	311mm	225mm	55mm	110mm	M20	42mm	20mm	400mm	350mm	450mm	19mm	5mm	-	-	-	-	-
225 M	356mm	286mm	311mm	225mm	60mm	140mm	M20	42mm	20mm	400mm	350mm	450mm	19mm	5mm	-	-	-	-	-
250 S	406mm	311mm	349mm	250mm	60mm	140mm	M20	42mm	24mm	500mm	450mm	550mm	19mm	5mm	-	-	-	-	-
250 M	406mm	311mm	349mm	250mm	65mm	140mm	M20	42mm	24mm	500mm	450mm	550mm	19mm	5mm	-	-	-	-	-
280 S	457mm	368mm	419mm	280mm	65mm	140mm	M20	42mm	23mm	500mm	450mm	550mm	18mm	5mm	-	-	-	-	-
280 M	457mm	368mm	419mm	280mm	75mm	140mm	M20	42mm	23mm	500mm	450mm	550mm	18mm	5mm	-	-	-	-	-
315 S, 2p	508mm	406mm	457mm	315mm	65mm	140mm	M20	40mm	25mm	600mm	550mm	660mm	23mm	6mm	-	-	-	-	-
315 S, 4p-8p	508mm	406mm	457mm	315mm	80mm	170mm	M20	40mm	25mm	600mm	550mm	660mm	23mm	6mm	-	-	-	-	-
315 M, 2p	508mm	457mm	508mm	315mm	65mm	140mm	M20	40mm	25mm	600mm	550mm	660mm	23mm	6mm	-	-	-	-	-
315 M, 4-8p	508mm	457mm	508mm	315mm	90mm	170mm	M24	48mm	25mm	600mm	550mm	660mm	23mm	6mm	-	-	-	-	-
355 S, 2p	610mm	500mm	560mm	355mm	70mm	140mm	M20	42mm	35mm	740mm	680mm	800mm	23mm	6mm	-	-	-	-	-
355 S, 4-8p	610mm	500mm	560mm	355mm	100mm	210mm	M24	51mm	35mm	740mm	680mm	800mm	23mm	6mm	-	-	-	-	-
355 M, 2p	610mm	560mm	630mm	355mm	70mm	140mm	M20	42mm	35mm	740mm	680mm	800mm	23mm	6mm	-	-	-	-	-
355 M, 4-8p	610mm	560mm	630mm	355mm	100mm	210mm	M24	51mm	35mm	740mm	680mm	800mm	23mm	6mm	-	-	-	-	-
355 L, 2p	610mm	630mm	710mm	355mm	70mm	140mm	M20	42mm	35mm	740mm	680mm	800mm	23mm	6mm	-	-	-	-	-
355 L, 4-8p	610mm	630mm	710mm	355mm	100mm	210mm	M24	51mm	35mm	740mm	680mm	800mm	23mm	6mm	-	-	-	-	-

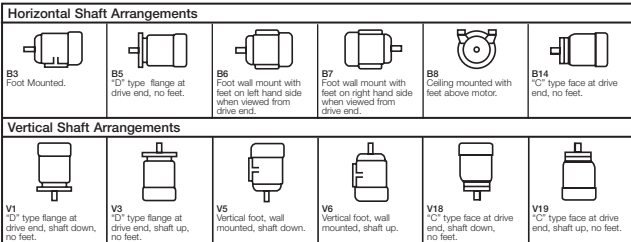

Legend
 1 mm = .03937"
 1" = 25.40 mm

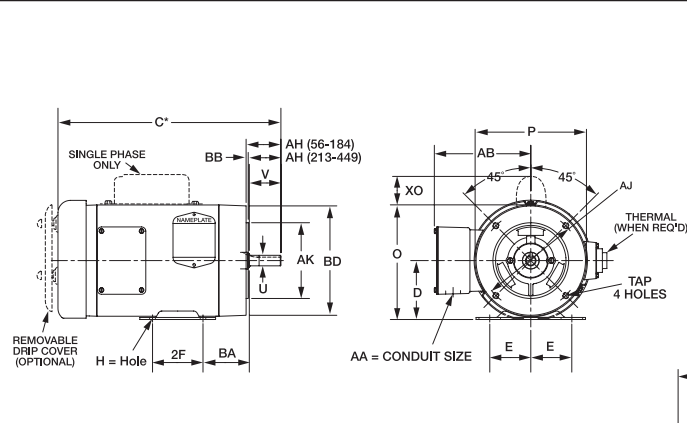

NEMA Shaft (U)	Keyseat Dimensions (R) (S)		NEMA Shaft (U)	Keyseat Dimensions (R) (S)	
	(R)	(S)		(R)	(S)
3/8	21/64	FLAT	1-7/8	1-19/32	1/2
1/2	29/64	FLAT	2-1/8	1-27/32	1/2
5/8	33/64	3/16	2-3/8	2-1/64	5/8
7/8	49/64	3/16	2-1/2	2-3/16	5/8
1-1/8	63/64	1/4	2-7/8	2-29/64	3/4
1-3/8	1-13/64	5/16	3-3/8	2-7/8	7/8
1-5/8	1-13/32	3/8	3-7/8	3-5/16	1

Drawings represent standard TEFC general purpose motors.
 *Dimensions are for reference only.

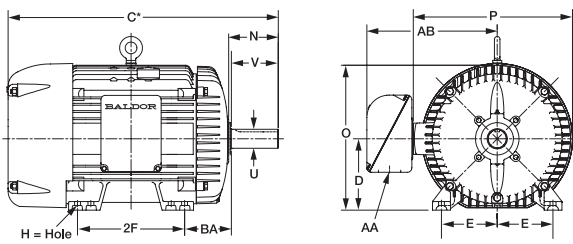

*Contact your local Baldor Sales Office for "C" Dimensions. Dimensions - N, O, P, AB and XO are specific to Baldor.

NEMA QUICK REFERENCE CHART

NEMA FRAME	D	E	2F	H	N	O	P	U	V	AA	AB	AH	AJ	AK	BA	BB	BD	XO	TAP
42	2-5/8	1-3/4	1-11/16	9/32 SLOT	1-1/2	5	4-11/16	3/8	1-1/8	3/8	4-1/32	1-5/16	3-3/4	3	2-1/16	1/8	4-5/8	1-9/16	1/4-20
48	3	2-1/8	2-3/4	11/32 SLOT	1-7/8	5-7/8	5-11/16	1/2	1-1/2	1/2	4-3/8	1-11/16	3-3/4	3	2-1/2	1/8	5-5/8	2-1/4	1/4-20
56 56H	3-1/2	2-7/16	3	11/32 SLOT	2-7/16	6-7/8	6-5/8	5/8	1-7/8	1/2	5	2-1/16	5-7/8	4-1/2	2-3/4	1/8	6-1/2	2-1/4	3/8-16
143T 145T	3-1/2	2-3/4	4	5	2-1/2	6-7/8	6-5/8	7/8	2-1/4	3/4	5-1/4	2-1/8	5-7/8	4-1/2	2-1/4	1/8	6-1/2	2-1/4	3/8-16
182 184 182T 184T	4-1/2	3-3/4	4-1/2	11/32	2-11/16	8-11/16	7-7/8	7/8	2-1/4	3/4	5-7/8	2-1/8	5-7/8	4-1/2	2-3/4	1/8	6-1/2	2-3/8	3/8-16
213 215 213T 215T	5-1/4	4-1/4	5-1/2	13/32	3-1/2	10-1/4	9-9/16	1-1/8	3	1	7-3/8	2-3/4	3-1/8	8-1/2	3-1/2	1/4	9	2-3/4	1/2-13
254U 256U 254T 256T	6-1/4	5	8-1/4	17/32	4-1/16	12-7/8	12-15/16	1-3/8	3-3/4	1	9-5/8	3-1/2	3-1/2	8-1/2	4-1/4	1/4	10	-	1/2-13
284U 286U 284T 286T 284TS 286TS	7	5-1/2	9-1/2	17/32	5-1/8	14-5/8	14-5/8	1-5/8	4-7/8	1-1/2	13-1/8	4-5/8	4-3/8	10-1/2	4-3/4	1/4	11-1/4	-	1/2-13
324U 326U 324T 326T 324TS 326TS	8	6-1/4	10-1/2	21/32	5-7/8	16-1/2	16-1/2	1-7/8	5-5/8	2	14-1/8	5-3/8	5-3/8	12-1/2	5-1/4	1/4	13-3/8	-	5/8-11
364U 366U 364T 366T 364TS 366TS	9	7	11-1/4	21/32	6-3/4	18-1/2	19-1/2	2-1/8	6-3/8	3	18-1/16	6-1/8	5-5/8	12-1/2	5-7/8	1/4	13-3/8	-	5/8-11
404U 405U 404T 405T 404TS 405TS	10	8	12-1/4	13/16	7-3/16	21-5/16	22-1/2	2-3/8	7-1/8	3	19-1/16	6-7/8	6-7/8	12-1/2	6-5/8	1/4	13-7/8	-	5/8-11
444U 445U 444T 445T 447T 449T 444TS 445TS 447TS 449TS	11	9	14-1/2	13/16	8-5/8	24.24	27.57	2-7/8	8-5/8	3	22.68	8-3/8	8-3/8	16	7-1/2	1/4	16-3/4	-	5/8-11

The above chart provides typical Baldor-Reliance motor dimensions. For more exact dimensional data, please check the specific drawing for each catalog number. NEMA states only a minimum value for AA dimension. AA dimensions shown in chart are Baldor typical values meeting or exceeding NEMA. Please check motor drawing for actual dimensions.

Frame L449T is not included in this chart. Please refer to the Large AC motor chart, or to the specific motor drawings for L449T dimensions.

NEMA C-Face	BA Dimensions
143-5TC	2-3/4
182-4TC	3-1/2
213-5TC	4-1/4
254-6TC	4-3/4

BALDOR ELECTRIC COMPANY
 P.O. BOX 2400
 FORT SMITH, ARKANSAS
 72902-2400 U.S.A.

Frame	NEMA FRAMES PRIOR TO 1953							
	D	E	F	N	U	V	BA	
68	4-1/8	2-15/16	2-1/2	2-1/4	3/4	2-1/4	3-1/8	
203	5	4	2-3/4	2-7/16	3/4	2	3-1/8	
204			3-1/4					
224	5-1/2	4-1/2	3-3/8	3-1/4	1	3	3-1/2	
225			3-3/4					
254	6-1/4	5	4-1/8	3-7/16	1-1/8	3-3/8	4-1/4	
284	7	5-1/2	4-3/4	4-1/4	1-1/4	3-3/4	4-3/4	
324			5-1/4					
326	8	6-1/4	6	5-3/8	1-5/8	4-7/8	5-1/4	
364			6-1/8					
365	9	7	6-1/8	5-5/8	1-7/8	5-3/8	5-7/8	
404			6-1/8					
405	10	8	6-7/8	6-3/8	2-1/8	6-1/8	6-5/8	
444			7-1/4					
445	11	9	8-1/4	7-1/8	2-3/8	6-7/8	7-1/2	
504			8					
505	12-1/2	10	9	8-5/8	2-7/8	8-3/8	8-1/2	